

Solenoid Valve - 2/2 - Normally Closed - Position Feedback

Benefits & Features

- Position feedback switch with LED indicator, 2m cable
- Switch current consumption: ≤15mA, Load current 200mA
- Sensor output type: NC. The LED (red) lights up when the solenoid valve is open
- Suitable for water, liquids, air etc.
- Media temperature: -10°C to +70°C
- Two way normally closed, Lift assisted pilot
- Brass, 304 stainless steel or cast iron body (2 1/2" to 4")
- NBR, VITON or EPDM seals
- IP65 protection (coil), IP68 (position switch)
- #410 solenoid coil 220VAC. #510 solenoid coil 24VDC



Specification

Configuration	Pilot operated lift assisted design
Port Sizes	1/2" to 2" BSP, 2 1/2" - 4" Cast Iron flanged
Orifice	see table below
Cv	see table below
Body	Brass
Media	Air, water, liquids etc. Subject to material compatibility
Pressure ranges	0 - 7bar, 0 - 6bar, 0.3 - 7bar. Subject to control voltage & port size
Seals	NBR, VITON or EPDM -10 to +70°C
Voltage	#410 solenoid coil 220VAC. #510 solenoid coil 24VDC Other voltages upon request



Technical Data

	A	B	C	D	Orifice mm	Min. /Max. Operating Differential Pressures. BAR		Cv Flow Factor	
						Normally Closed			
						220VAC	24VDC		
BX41	15	F		P	1/2"	15	0 - 7 bar	0 - 6 bar	4.8
BX41	20	H		P	3/4"	20	0 - 7 bar	0 - 6 bar	7.6
BX41	25	L		P	1"	25	0 - 7 bar	0 - 6 bar	12
BX41	32	N		P	1 1/4"	32	0 - 7 bar	0 - 6 bar	24
BX41	40	O		P	1 1/2"	40	0 - 7 bar	0 - 6 bar	29
BX41	50	P		P	2"	50	0 - 7 bar	0 - 6 bar	48
BX41	65	FL25		P	Cast Iron Flange	65	0.3 - 7 bar	0 - 6 bar	52
BX41	80	FL3		P		80	0.3 - 7 bar	0 - 6 bar	82
BX41	100	FL4		P		100	0.3 - 7 bar	0 - 6 bar	128

Solenoid Valve - 2/2 - Normally Closed - Position Feedback

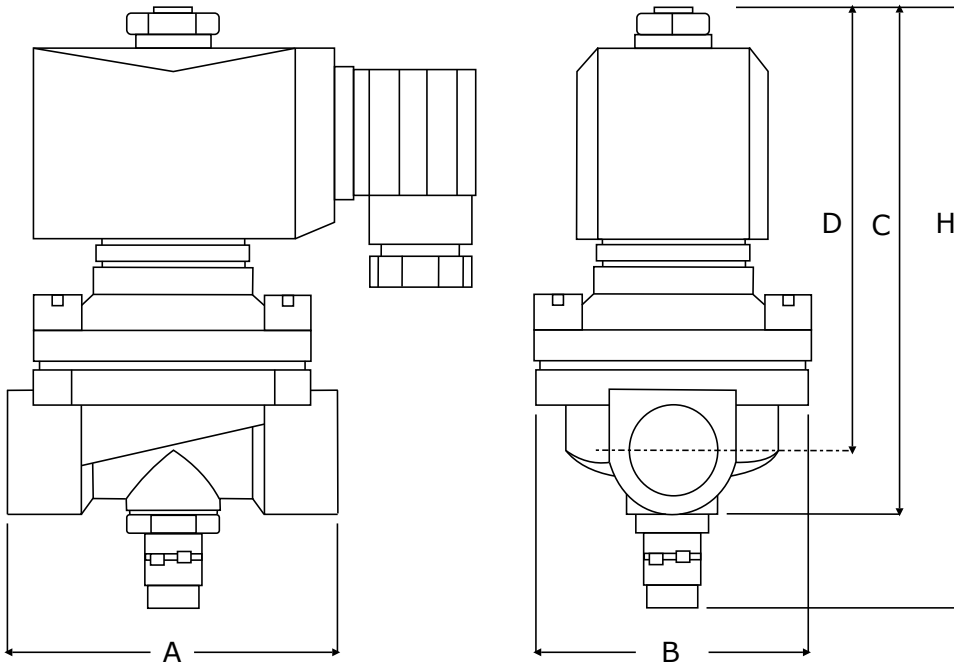

Dimensions mm

Port Size	Orifice mm	Dimensions mm				
		A	B	C	D	H
1/2"	15	68	56	105	91	140
3/4"	20	73	56	111	95	140
1"	25	100	74	124	103	140
1 1/4"	32	110	85	154	129	165
1 1/2"	40	120	90	162	134	180
2"	50	154	115	185	151	200
Cast Iron Flange	65	259	185	277	185	265
	80	278	200	289	189	275
	100	350	220	316	206	285

Order Codes

A	Body	B	Port	C	Seals	D	Protection		
C	Cast Iron*	F	1/2" BSP	H	3/4" BSP	0	NBR	P	IP65 Safe Area
H	304 Stainless Steel	L	1" BSP	N	1 1/4" BSP	1	VITON		
T	Brass	O	1 1/2" BSP	P	2" BSP	6	EPDM		
	* 2 1/2", 3", 4"	FL25	DN65	FL3	DN80				
		FL4	DN100						

Position Switch Electrical Wiring

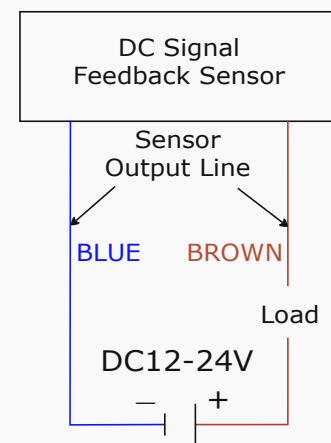

DC signal feedback device
External circuit diagram

Current consumption:
≤15mA
Load current consumption:
200mA

DIN electrical socket connectors to protect solenoid coil terminals and wiring.

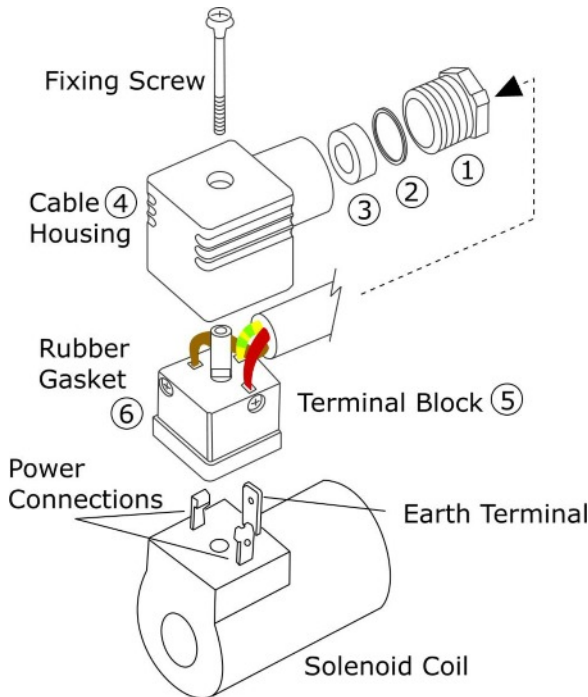

Section 1: DIN Connector Assembly

- Insert the electrical power cable through the gland assembly (1,2,3)
- Push the cable through cable housing (4)
- Connect power and earth cables to terminal block 5
- Push terminal block (5) backwards, inside cable housing (4)
- Place rubber gasket (6) on terminal block (5) front face
- Push terminal block onto solenoid coil terminals
- Push fixing screw through complete assembly
- Tighten fixing screw with small screwdriver
- Do not over tighten
- Tighten cable gland (1,2,3) by hand

Section 2: How to install Solenoid Valves

Solenoid Valves can normally be installed and operate in any orientation. However, certain models are designed to operate in horizontal installations. Please contact Red Dragon for further information.

Installation Procedure:

Check that the Solenoid Valve is the correct product ordered for the application:

- Isolate the site electrical power supply
- Isolate the site media supply (dependant on the application)...air, water, steam etc. Leave until cool/safe.
- Insert the valve onto the pipe, ensuring that the flow direction is observed....IN for incoming media, or an arrow stamped on the valve body.
- Ensure that the pipe connections are free from burrs or loose pipe thread tape
- Tighten all pipe joints
- Connect electrical power supply via DIN electrical socket connector, as detailed in section 1
- Ensure that DIN connector is properly connected to solenoid coil and the gasket is installed correctly
- Apply media pressure and check for leaks

Section 3: Maintenance Procedure for Solenoid Valves

In the unlikely event of a valve malfunction, or routine maintenance, follow these instructions:

- Isolate the site electrical power supply
- Isolate the site media supply (dependant on the application)...air, water, steam etc.
- Remove the solenoid coil by unscrewing the coil retention nut anti-clockwise
- Remove the coil tube stem by unscrewing anti-clockwise
- Carefully remove the plunger assembly (inside the coil stem)
- Check the plunger assembly for damage or worn seals
- Check the face inside the coil stem for foreign particles that could prevent correct operation
- For Pilot Diaphragm Solenoid Valves: remove the top cover housing and check the diaphragm for damage and blocked transfer port.
- Re-assemble the valve in reverse order, ensuring that all parts are cleaned and assembled correctly